

EXTREME POWER

XP SERIES



www.ferromc.com



46-271 STANDARD CONTROL

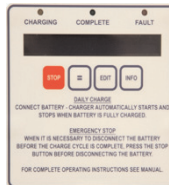

Full of features suitable for fleets of all sizes

46-272 CONTROL

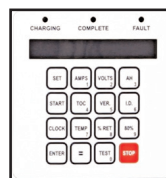

Upgrade for full battery management capabilities

100% 8 HR CHARGER

Single and Three Phase Models Available

SUPERIOR QUALITY

Built to meet Battery Council International Performance Standards

FULLY AUTOMATIC

Only requires connection to the battery. Charger control monitors performance and reports errors.

CONTROL OPTIONS

Use our standard control or upgrade to the 46-272 for a full battery management system

RUGGED CASE

Sturdy cabinet design allows stacking up to three units

EFFICIENT DESIGN

High power factor and energy efficiency

LOW MAINTENANCE

Simple and proven design provides years of trouble-free service.

HEAVY DUTY RATING

Engineered for three shift applications

FAIL-SAFE OPERATION

Industry-proven ferro-resonant circuitry protects against battery overcharge and incorrect battery connections.

- ISOLATION**
DC components are mounted away from AC transient noise
- QUICK CHANGEOVER**
AC Input taps are easily accessed when needed
- OVERSIZED HEAT SINK**
Reduces diode operating temperatures
- CASE DESIGN**
Exceptional Cooling for long component life
- TRANSFORMER MOUNTING**
Maximizes air flow across copper windings
- EASY ACCESS**
AC fuses and AC taps are easily accessed for improved servcability
- CONTROL OPTIONS**
Common connector makes upgrade a snap
- DOOR DESIGN**
Easy lift-off door

CHARGER PERFORMANCE *at a glance*

Shifts

Duty Cycle LIGHT MED HEAVY

Charging Rate LOW MED HIGH

Recharge Time 6 HOURS 8 HOURS 12 HOURS



LISTED
BATTERY CHARGER



XP MODEL AND PERFORMANCE MATRIX

Cells	Amp Hour Capacity		Single Phase								Three Phase							
			Model Number	DC Amps Output	AC Input Amps				Case Size	Shipping Weight	Model Number	DC Amps Output	AC Input Amps				Case Size	Shipping Weight
	AH	Range			120V	208V	240V	480V					208V	240V	480V			
6	260	181-260	XPS6-260*	47	6.6	3.8	3.3	1.6	500	70								
	380	261-380	XPS6-380*	69	9.7	5.6	4.8	2.4	500	79	XPT6-380*	69	3.2	2.8	1.4	501	164	
	475	381-475	XPS6-475*	86	12	6.9	6.0	3.0	500	82	XPT6-475*	86	4.0	3.5	1.7	501	164	
	600	476-600	XPS6-600*	108	15.1	8.7	7.6	3.8	500	88	XPT6-600*	108	5.0	4.4	2.2	501	164	
	750	601-750	XPS6-750*	135	18.9	10.9	9.5	4.7	500	88	XPT6-750*	135	6.3	5.5	2.7	501	164	
	865	751-865	XPS6-865*	156	21.8	12.6	10.9	5.5	501	168	XPT6-865*	156	7.3	6.3	3.2	501	182	
	965										XPT6-965*	174	8.1	7.0	3.5	501	182	
	1050										XPT6-1050*	189	8.8	7.6	3.8	501	182	
	1200										XPT6-1200*	216	10.1	8.7	4.4	501	191	
	1450										XPT6-1450*	261	12.2	10.6	5.3	501	202	
12	260	181-260	XPS12-260*	47	13.2	7.6	6.6	3.3	500	82								
	380	261-380	XPS12-380*	69	19.3	11.1	9.7	4.8	500	96	XPT12-380*	69	6.4	5.6	2.8	501	164	
	475	381-475	XPS12-475*	86	-	13.9	12	6.0	501	160	XPT12-475*	86	8.0	7.0	3.5	501	182	
	600	476-600	XPS12-600*	108	-	17.4	15.1	7.6	501	173	XPT12-600*	108	10.1	8.7	4.4	501	191	
	750	601-750	XPS12-750*	135	-	21.8	18.9	9.5	501	173	XPT12-750*	135	12.6	10.9	5.5	501	202	
	865	751-865	XPS12-865*	156	-	25.2	21.8	10.9	501	190	XPT12-865*	156	14.6	12.6	6.3	501	220	
	965	866-965	XPS12-965*	174	-	28.1	24.4	12.2	501	207	XPT12-965*	174	16.2	14.1	7.0	501	220	
	1050										XPT12-1050*	189	17.6	15.3	7.6	501	220	
	1200										XPT12-1200*	216	20.2	17.5	8.7	501	243	
	1450										XPT12-1450*	261	24.4	21.1	10.6	501	268	
1750										XPT12-1750*	315	29.4	25.5	12.7	502	307		
18	260	181-260	XPS18-260*	47	19.7	11.4	9.9	4.9	500	96								
	380	261-380	XPS18-380*	69	30	16.7	14.5	7.2	500	160	XPT18-380*	69	9.7	8.4	4.2	501	191	
	475	381-475	XPS18-475*	86	36.1	20.8	18.1	9.0	501	190	XPT18-475*	86	12.0	10.4	5.2	501	191	
	600	476-600	XPS18-600*	108	45.4	26.2	22.7	11.3	501	190	XPT18-600*	108	15.1	13.1	6.6	501	220	
	750	601-750	XPS18-750*	135	-	32.7	28.4	14.2	501	227	XPT18-750*	135	18.9	16.4	8.2	501	243	
	865	751-865	XPS18-865*	156	-	37.8	32.8	16.4	501	227	XPT18-865*	156	21.8	18.9	9.5	501	243	
	965	866-965	XPS18-965*	174	-	42.2	36.5	18.3	501	227	XPT18-965*	174	24.4	21.1	10.6	501	268	
	1050										XPT18-1050*	189	26.5	22.9	11.5	501	268	
	1200										XPT18-1200*	216	30.3	26.2	13.1	501	307	
	1450										XPT18-1450*	261	36.6	31.7	15.8	502	466	
1750										XPT18-1750*	315	44.1	38.2	19.1	502	466		
24	260	181-260	XPS24-260*	47	-	15.2	13.2	6.6	500	104								
	380	261-380	XPS24-380*	69	-	22.3	19.3	9.7	501	168	XPT24-380*	69	12.9	11.2	5.6	501	202	
	475	381-475	XPS24-475*	86	-	27.8	24.1	12	501	190	XPT24-475*	86	16.1	13.9	7.0	501	220	
	600	476-600	XPS24-600*	108	-	34.9	30.2	15.1	501	207	XPT24-600*	108	20.2	17.5	8.7	501	243	
	750	601-750	XPS24-750*	135	-	43.6	37.8	18.9	501	227	XPT24-750*	135	25.2	21.8	10.9	501	268	
	865	751-865	XPS24-865*	156	-	-	43.7	21.8	501	242	XPT24-865*	156	29.1	25.2	12.6	501	268	
	965	866-965	XPS24-965*	174	-	-	-	24.4	501	242	XPT24-965*	174	32.5	28.2	14.1	501	307	
	1050	966-1050									XPT24-1050*	189	35.3	30.6	15.3	502	307	
	1200	1051-1200									XPT24-1200*	216	40.3	35.0	17.5	502	376	
	1450	1201-1450									XPT24-1450*	261	-	42.2	21.1	502	411	
1750	1451-1750									XPT24-1750*	315	-	-	25.5	502	591		
2200	1751-2200									XPT24-2200*	396	-	-	32	502	697		

*Requires AC Voltage Code

AC Voltage	1Φ	3Φ
120/208/240	A	N/A
208/240/480	B	B
480/575	N/A	K

CASE DIMENSIONS

Case	Height		Width		Depth	
	in	cm	in	cm	in	cm
500	20.5	52.0	17.3	44.0	14.8	37.6
501	26	66.0	24.3	61.7	24.6	65.5
502	28	71.1	38.3	97.2	27.6	70.1

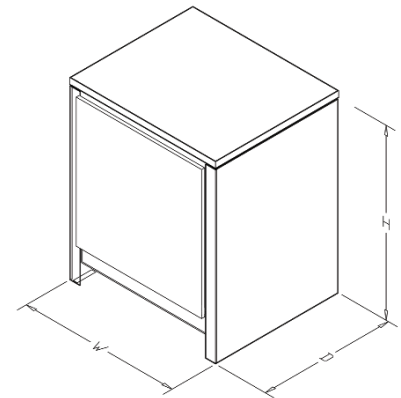

your **EXTREME POWER** Dealer:

